



# Standard Test Method for Flash Point and Fire Point of Liquids by Tag Open-Cup Apparatus<sup>1</sup>

This standard is issued under the fixed designation D 1310; the number immediately following the designation indicates the year of original adoption or, in the case of revision, the year of last revision. A number in parentheses indicates the year of last reapproval. A superscript epsilon ( $\epsilon$ ) indicates an editorial change since the last revision or reapproval.

*This standard has been approved for use by agencies of the Department of Defense.*

## 1. Scope

1.1 This test method covers the determination by Tag Open-Cup Apparatus of the flash point and fire point of liquids having flash points between  $-18$  and  $165^{\circ}\text{C}$  ( $0$  and  $325^{\circ}\text{F}$ ) and fire points up to  $325^{\circ}\text{F}$ .

1.2 This test method, when applied to paints and resin solutions that tend to skin over or that are very viscous, gives less reproducible results than when applied to solvents.

NOTE 1—In order to conserve time and sample, the fire point of a material may be determined by the Tag Open-Cup Method by continuing the heating of the specimen to its fire point. Fire points may also be determined by Test Method D 92, which should be used for fire points beyond the scope of this test method.

1.3 The values stated in SI units are to be regarded as the standard. The values given in parentheses are for information only.

1.4 *This standard should be used to measure and describe the properties of materials, products, or assemblies in response to heat and flame under controlled laboratory conditions and should not be used to describe or appraise the fire hazard or fire risk of materials, products, or assemblies under actual fire conditions. However, results of this test may be used as elements of a fire risk assessment which takes into account all of the factors pertinent to an assessment of the fire hazard of a particular end use.*

1.5 *This standard does not purport to address the safety problems associated with its use. It is the responsibility of the user of this standard to establish appropriate safety and health practices and determine the applicability of regulatory limitations prior to use.*

<sup>1</sup> This test method is under the jurisdiction of ASTM Committee D01 on Paint and Related Coatings, Materials, and Applications and is the direct responsibility of Subcommittee D01.22 on Flammability and Safety.

Current edition approved June 1, 2007. Published August 2007. Originally approved in 1952. Last previous edition approved in 2001 as D 1310 – 01.

## 2. Referenced Documents

### 2.1 ASTM Standards:<sup>2</sup>

D 92 Test Method for Flash and Fire Points by Cleveland Open Cup Tester

D 850 Test Method for Distillation of Industrial Aromatic Hydrocarbons and Related Materials

D 1015 Test Method for Freezing Points of High-Purity Hydrocarbons

D 1016 Test Method for Purity of Hydrocarbons from Freezing Points

D 1078 Test Method for Distillation Range of Volatile Organic Liquids

D 1364 Test Method for Water in Volatile Solvents (Karl Fischer Reagent Titration Method)

D 2268 Test Method for Analysis of High-Purity *n*-Heptane and Isooctane by Capillary Gas Chromatography

D 2699 Test Method for Research Octane Number of Spark-Ignition Engine Fuel

D 2700 Test Method for Motor Octane Number of Spark-Ignition Engine Fuel

E 1 Specification for ASTM Liquid-in-Glass Thermometers

## 3. Terminology

### 3.1 Definitions:

3.1.1 *flash point, n*—the lowest temperature, corrected to a pressure of 760 mm Hg (101.3 kPa, 1013 mbar), at which application of an ignition source causes the vapor of the specimen to ignite by the procedure described.

### 3.2 Definitions of Terms Specific to This Standard:

3.2.1 *fire point, n*—the lowest temperature at which a specimen sustains burning for a minimum of 5 s by the procedure described.

<sup>2</sup> For referenced ASTM standards, visit the ASTM website, [www.astm.org](http://www.astm.org), or contact ASTM Customer Service at [service@astm.org](mailto:service@astm.org). For *Annual Book of ASTM Standards* volume information, refer to the standard's Document Summary page on the ASTM website.

#### 4. Summary of Method

4.1 The specimen is placed in the cup of a Tag Open-Cup Apparatus and heated at a slow, but constant rate. A small test flame is passed at a uniform rate across the cup at specified intervals until a flash occurs. To determine the fire point, the test is continued until the application of the test flame causes the specimen to ignite and burn for at least 5 s.

#### 5. Significance and Use

5.1 Flash point and fire point of a liquid are physical properties that may be used to define their flammability hazards. The flash point may be used to classify materials in government regulations.

#### 6. Apparatus

6.1 *Flash Tester*—Tag Open-Cup Apparatus (Fig. 1), as described in detail in Annex A1.

6.2 *Shield*, as described in detail in Annex A1.

6.3 *Thermometers*, conforming to Specification E 1, as listed in Table 1.

6.4 *Flasks*, 500-mL, two, with rubber stoppers.

#### 7. Materials

7.1 *Water-Glycol Solution* (1 + 1), for flash points from  $-18$  to  $93^{\circ}\text{C}$  ( $0$  to  $200^{\circ}\text{F}$ ).

7.2 *Solid Carbon Dioxide-Acetone or other Coolant*.

7.3 *Silicone Fluid*, inert, high boiling, having a flash point exceeding the test temperatures by at least  $60^{\circ}\text{C}$  ( $110^{\circ}\text{F}$ ) for flash and fire points from  $93$  to  $165^{\circ}\text{C}$  ( $200$  to  $325^{\circ}\text{F}$ ).

7.4 *n-Heptane*,<sup>3</sup> for determination of flash points from  $-18$  to  $16^{\circ}\text{C}$  ( $0$  to  $60^{\circ}\text{F}$ ). See Annex A2 for specifications.

7.5 *p-Xylene*,<sup>3</sup> for determination of flash points from  $16$  to  $93^{\circ}\text{C}$  ( $60$  to  $200^{\circ}\text{F}$ ). See Annex A2 for specifications.

7.6 *Isopropanol (isopropyl alcohol)*,<sup>4</sup> for determination of flash points from  $16$  to  $93^{\circ}\text{C}$  ( $60$  to  $200^{\circ}\text{F}$ ). See Annex A2 for specifications.

7.7 *Diethylene Glycol*,<sup>5</sup> for determination of flash points from  $93$  to  $165^{\circ}\text{C}$  ( $200$  to  $325^{\circ}\text{F}$ ). See Annex A2 for specifications.

#### 8. Assembly and Preparation of Apparatus

8.1 Place the tester in a level position on a solid table free of vibration, in a location free of perceptible draft, and in a dim light. Maintain a room temperature of  $24 \pm 3^{\circ}\text{C}$  ( $75 \pm 5^{\circ}\text{F}$ ) throughout the test. Other room temperatures may be specified on agreement between buyer and seller.

NOTE 2—For materials with vapors or products of pyrolysis that are objectionable, it is permissible to place the apparatus with shield in a fume hood with the ventilation turned off. The ventilation can then be turned on at completion of the test, or when and if fumes become objectionable.

<sup>3</sup> Satisfactory *n*-heptane and *p*-xylene can be obtained from Special Products Division, Chemical Department, Phillips Petroleum Company, Drawer O, Borger, TX 79607.

<sup>4</sup> Satisfactory isopropanol may be obtained from Exxon Chemical, Americus P. O. Box 3272, Houston, TX 77001, Shell Chemical Co., One Shell Plaza, Houston, TX 77002, or Union Carbide Co., P. O. Box 8361, South Charleston, WV 25303.

<sup>5</sup> Satisfactory diethylene glycol may be obtained from Union Carbide Co., S. Charleston, WV.

8.2 Adjust the horizontal and vertical positions of the taper so that the jet passes on the circumference of a circle having a radius of at least 6 in. (150 mm). The jet should pass across the center of the cup at right angles to a diameter passing through the thermometer and in a plane  $\frac{1}{8}$  in. (3.2 mm) above the upper edge of the cup as measured from the center of the orifice.

8.3 Using the leveling device as a gage, adjust the height of the taper so that the center of the orifice is exactly  $\frac{1}{8}$  in. (3.2 mm) above the top edge of the glass cup when it is in place. It is imperative that this adjustment be made as accurately as possible. Raising or lowering the taper can be achieved by bending it slightly or preferably by adding and removing thin metal shims as required from between the taper and the vertical supporting member of the swivel holder.

8.4 With the glass cup in place in the bath, adjust the thermometer holder so that the thermometer is supported firmly in a vertical position halfway between the center and edge of the cup and on a line passing through the center of the cup and the pivot of the taper. Place the thermometer so that the bottom of the bulb is  $\frac{1}{4}$  in. (6.4 mm) from the inner bottom of the cup.

8.5 Set the draft shield around the tester so that the sides form right angles with each other and the tester is well toward the back of the shield.

#### 9. Procedure

9.1 *Flash Points from  $-18$  to  $16^{\circ}\text{C}$  ( $0$  to  $60^{\circ}\text{F}$ )* (**Warning**—Meticulous attention to all details relating to the taper, size of taper flame, rate of temperature increase, and rate of passing the taper over the sample is necessary for good results.)

9.1.1 Equip two 500-mL flasks with rubber stoppers through which are inserted ASTM 33C (33F) thermometers. Cool a quantity of 1 + 1 water-glycol solution in one stoppered 500-mL flask to approximately  $-30^{\circ}\text{C}$  ( $-20^{\circ}\text{F}$ ) by immersing the flask in a solid carbon dioxide-acetone bath or other coolant. Use extreme care not to contaminate the water-glycol solution with either acetone or carbon dioxide.

9.1.2 Pour the cooled water-glycol solution into the tester bath to a predetermined level 3.2 mm ( $\frac{1}{8}$  in.) below the top when the cup is in place. An overflow is desirable for controlling the liquid level in the bath.

9.1.3 At the same time the water-glycol coolant is being chilled, cool a portion of the sample to approximately  $-25^{\circ}\text{C}$  ( $-10^{\circ}\text{F}$ ) in the second stoppered 500-mL flask. If solid carbon dioxide and acetone or other volatile solvents are used as a coolant, extreme care must be exercised to avoid contamination of the sample. Cool the glass cup and place it in the bath. Position the appropriate thermometer (Table 1) as described in 8.4 and fill the cup with cooled sample to a depth approximately 3.2 mm ( $\frac{1}{8}$  in.) below the edge as determined by the leveling device.

NOTE 3—Remove all bubbles from the surface of the liquid before starting a determination.

9.1.4 Light the ignition flame and adjust it to form a flame of spherical shape matching in size the  $\frac{5}{32}$ -in. (4.0-mm) sphere on the apparatus or the  $\frac{5}{32}$ -in. hole in the leveling device.

9.1.5 Make the final adjustment of the specimen level in the cup when the temperature is  $20^{\circ}\text{F}$  ( $10^{\circ}\text{C}$ ) below the anticipated flash point. Two trial determinations may be necessary to select

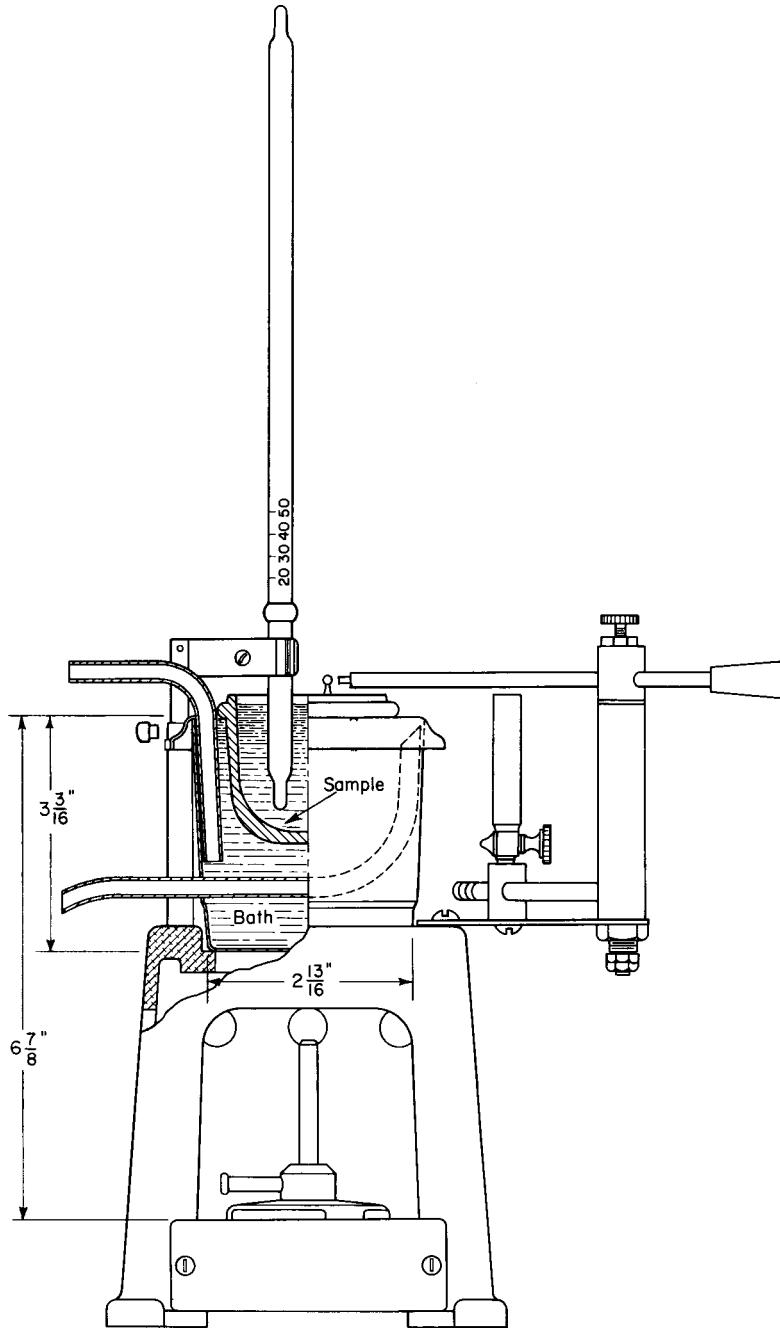

Metric Equivalents

in.	mm
2 <sup>13</sup> / <sub>16</sub>	71.4
3 <sup>3</sup> / <sub>16</sub>	81
6 <sup>7</sup> / <sub>8</sub>	174.5

FIG. 1 Tag Open-Cup Apparatus

the proper temperature at which to adjust the liquid level. A hypodermic syringe or medicine dropper provides a convenient means of adding or removing sample from the cup.

9.1.6 Allow the temperature of the specimen to increase spontaneously—without applying any heat—until the rate of temperature rise decreases to 2°F (1°C)/min. At this point,